



**HVAL**  
A  HANKUN Brand



# VALVE

HANKUN QUALITY | DRIVING THE FUTURE

ZERO LEAKAGE, MAINTENANCE-FREE



Tel: +86-(0)10-63260308  
Fax: +86-(0)10-63265498  
Email: info@hankunchina.com



[www.hankunfluid.com](http://www.hankunfluid.com)

Hankun (Beijing) Fluid Control Technology Co. , Ltd.

## Company Introduction

Hankun was founded in 2007 with a vision to become a "respected international expert in fluid control". Hankun independently develops and produces IoT hose pumps, unattended dosing devices, IoT electric actuators, pneumatic actuators, valves. Hankun is the world-leading supplier in fluid control products and services.

Hankun is headquartered in Beijing with the factory in Shanghai and branch offices in Xi'an, Chengdu, Changsha, Guangzhou and other cities. Furthermore, Hankun has authorized distributors in Canada, Singapore, Indonesia, Thailand, Russia, Uzbekistan, Pakistan, India and other countries and regions, ensuring a robust and efficient sales network and service system.

With the mission of "Making fluid control more reliable and simpler under harsh working conditions of special media", Hankun has long been dedicated to providing professional fluid control solutions for industries such as power plant, petrochemicals, water treatment and other process industries. Through the necessary on-site surveys and technical exchanges, Hankun recommends safe, cost-effective, environmentally friendly solution and design based on the actual site conditions, effectively addressing issues such as leaks and blockages.

Reputation is paramount for Hankun. We strictly adhere to contractual obligations by providing timely delivery, installation guidance, and commissioning to ensure compliance and smooth handover for customer use. Throughout the entire lifecycle, we provide whole process and considerate service.

Choose Hankun, Choose reliable, easy and satisfied.

## Qualifications





Product Overviews

Features

- Special medium harsh working condition
- Maintenance-free No-leakage
- Corrosion & Abrasion resistance
- High pressure drop High temperature difference

Function: on-off / regulating  
 Control Mode: electric / pneumatic  
 Valve Type: Butterfly Valve / Ball Valve / Globe Valve / Gate Valve / Single Seated Valve  
 Temperature: -196°C ~ 650°C  
 Pressure: 150lb ~ 2500lb  
 Nominal Diameter: DN15 ~ DN1800



1.

Butterfly Valve

Rubber Lined Butterfly Valve  
 Triple Offset Butterfly Valve

05-12



2.

Ball Valve

Trunnion Mounted Ball Valve

13-16

3.

Globe Valve

Globe Valve

17-20

4.

Gate Valve

Gate Valve

21-24

5.

Control Valve

Single Seated Valve  
 Single Seated Valve (Cage)

25-30

We realize there's a good chance that your control valves and instruments will need to last you decades-even in harsh environments. By selecting HIVAL control valves (butterfly/ball/gate/globe/single seated etc), HITORK actuators you can more easier meet your performance and safety requirements. This is possible because their as-designed performance integrity has been tested to ensure the highest degree of lasting reliability is achieved.

HIVAL valves and HITORK actuators can help you increase performance and safety from general to the most severe or critical service conditions you have experienced.



## RUBBER LINED BUTTERFLY VALVE

Pin Less Butterfly Plate



Pin Butterfly Plate



### Product Introduction

Rubber lined butterfly valves are a type of valve which can be used for isolating or regulating flow.

The closing mechanism is the disc which sits in the center of the valve body. The disc is connected to a handle or actuator via the shaft which passes from the disc through the top of the valve body.

Unlike a ball valve, the disc of the butterfly valve is always present in the flow, which will induce the pressure drop.

Compared with the ball valve, a butterfly valve can be shut off quickly but requires less support due to its lighter weight.

Rubber lined butterfly valves operate in a quarter turn, meaning that rotating the closed disc 90° will fully open the valve, and vice versa. They can also be opened incrementally in order to throttle flow.

This can be accomplished manually, but throttling flow will be more precise when an actuator is used cooperatively.

Actuators can be customized to allow incremental flow, by using positioners in the case of pneumatic and hydraulic actuators, or by using modulating boards in the case of electric actuators.

### Parts Material

Name	Material
Valve Body	Cast iron, nodular cast iron, carbon steel, 304/304L/316/316L
Valve Seat	NBR/EPDM/PTFE/VITON special rubber for desulfurization
Valve Plate	2507 dual phase steel/1.4529 dual phase steel/DI/WCB/CF8/CF8M/C954
The Stem	2Cr13/304/420/316

### Wafer

Main connection and external dimensions(mm)

#### ANSI CLASS150 & ISO PN10/16

Nominal Diameter		PN10		PN16		ANSI 150						
mm	Inch	L	H1	H2	W1	W2	D0	n-d	D0	n-d	D0	n-d
DN50	2	43	80	415	250	182	125	4-18	125	4-18	120.5	4-19
DN65	2-1/2	46	89	425	250	182	145	4-18	145	4-18	139.7	4-19
DN80	3	46	95	437	250	182	160	8-18	160	8-18	152.5	4-19
DN100	4	52	114	467	250	182	180	8-18	180	8-18	190.5	8-19
DN125	5	56	127	483	332	248	210	8-18	210	8-18	215.9	8-22
DN150	6	56	139	488	332	248	240	8-22	240	8-22	241.5	8-22
DN200	8	60	175	557	424	346	295	8-22	295	12-22	298.5	8-22
DN250	10	68	203	594	424	346	350	12-22	355	12-26	362	12-25
DN300	12	78	243	701	424	346	400	12-22	410	12-26	431.8	12-25
DN350	14	78	267	735	424	346	460	16-22	470	16-26	476.2	12-28.5
DN400	16	102	309	763	424	346	515	16-26	525	16-30	539.8	16-28.5
DN450	18	114	328	797	424	346	565	20-26	585	20-30	577	16-31.8
DN500	20	127	361	823	424	346	620	20-26	650	20-33	635	20-31.8
DN600	24	154	459	852	780	640	725	20-30	770	20-36	749.3	20-35
DN700	28	165	520	906	812	640	840	24-30	840	24-36	795.5	40-22
DN800	32	190	591	996	1042	640	950	24-33	950	24-39	864	48-22

\*Pneumatic actuators can be provided and equipped corresponding accessories, such as solenoid valve, positioners, air filter regulator and limit switch according to clients' requirements.

### Outline Drawing

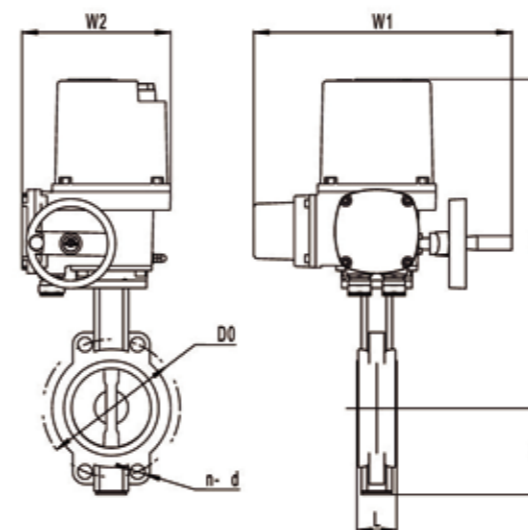

### Product Advantages

- Wafer&Flange connection, simple structure, compact, light weight, can be installed in any position.
- Pinless connection, zero leakage.
- Small flow resistance coefficient, large circulation capacity, good regulating.
- Axial thrust bearing or lubricated bronze to prevent overload of valve stem.

## RUBBER LINED BUTTERFLY VALVE

### Product Advantages

- The axis plate no pin connection, the structure is simple and light.
- Soft seal, zero leakage, long service life.
- 2507/1.4529 dual phase stainless steel valve, corrosion resistance, wear resistance.
- The surface of epoxy resin coating, anti-corrosion, beautiful.

### Outline Drawing

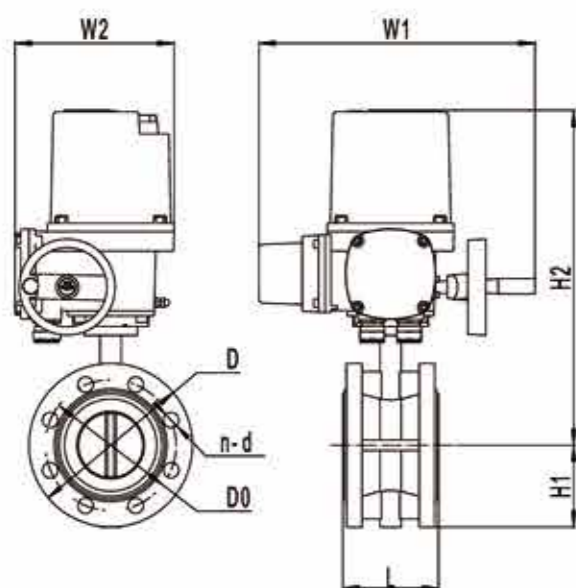

### Parts Material

Name	Material
Valve Body	Cast iron, nodular cast iron, carbon steel, 304/304L/316/316L
Valve Seat	NBR/EPDM/PTFE/VITON special rubber for desulfurization
Valve Plate	2507 dual phase steel/1.4529 dual phase steel/DI/WCB/CF8/CF8M/C954
The Stem	2Cr13/304/420/316



Flange

### Main connection and external dimensions(mm)

Nominal Diameter		ANSI CLASS150 & ISO PN10/16																
		PN10			PN16			ANSI 150										
mm	Inch	L	H1	H2	W1	W2	D	D0	n-d	D	D0	n-d	D	D0	n-d	D	D0	n-d
DN50	2	108	82	415	250	182	165	125	4-18	165	125	4-18	152	120.5	4-19			
DN65	2-1/2	112	92	425	250	182	185	145	4-18	185	145	4-18	178	139.7	4-19			
DN80	3	114	100	437	250	182	200	160	8-18	200	160	8-18	190	152.5	4-19			
DN100	4	127	110	467	250	182	200	180	8-18	200	180	8-18	229	190.5	8-19			
DN125	5	140	125	483	332	248	250	210	8-18	250	210	8-18	254	215.9	8-22			
DN150	6	140	142	488	332	248	285	240	8-22	285	240	8-22	279	241.5	8-22			
DN200	8	152	170	557	424	346	340	295	8-22	340	295	12-22	343	298.5	8-22			
DN250	10	165	197	594	424	346	395	350	12-22	405	355	12-26	406	362	12-25			
DN300	12	178	222	701	424	346	445	400	12-22	460	410	12-26	483	431.8	12-25			
DN350	14	190	252	735	424	346	505	460	16-22	520	470	16-26	533	476.2	12-28.5			
DN400	16	216	282	763	424	346	565	515	16-26	580	525	16-30	597	539.8	16-28.5			
DN450	18	222	307	797	424	346	615	565	20-26	640	585	20-30	635	577	16-31.8			
DN500	20	229	335	823	424	346	670	620	20-26	715	650	20-33	589	635	20-31.8			
DN600	24	267	390	852	780	640	780	725	20-30	840	770	20-36	813	749.3	20-35			
DN700	28	292	447	906	812	640	895	840	24-30	910	840	24-36	837	795.5	40-22			
DN800	32	318	507	996	1042	640	1015	950	24-33	1025	950	24-39	887	864	48-22			
DN900	36	330	557	996	1042	640	1115	1050	28-33	1125	1050	28-39	1057	1009.5	44-26			
DN1000	40	410	615	996	1042	640	1230	1380	28-36	1255	1170	28-42	1175	1121	44-30			

\*Pneumatic actuators can be provided and equipped corresponding accessories, such as solenoid valve, positioners, air filter regulator and limit switch according to clients' requirements.

## TRIPLE OFFSET BUTTERFLY VALVE

### Product Introduction

Triple Offset Butterfly Valves are essential in applications where bubble-tight shut-off is required. In some applications, bubble-tight shut-off cannot be achieved using double offset butterfly valves.

Some applications do not lend themselves well to traditional butterfly valves, for example applications involving harsh chemicals or media with small particles prone to clogging valves and pipelines.

In such applications, Triple Offset Technology offers superior benefits.

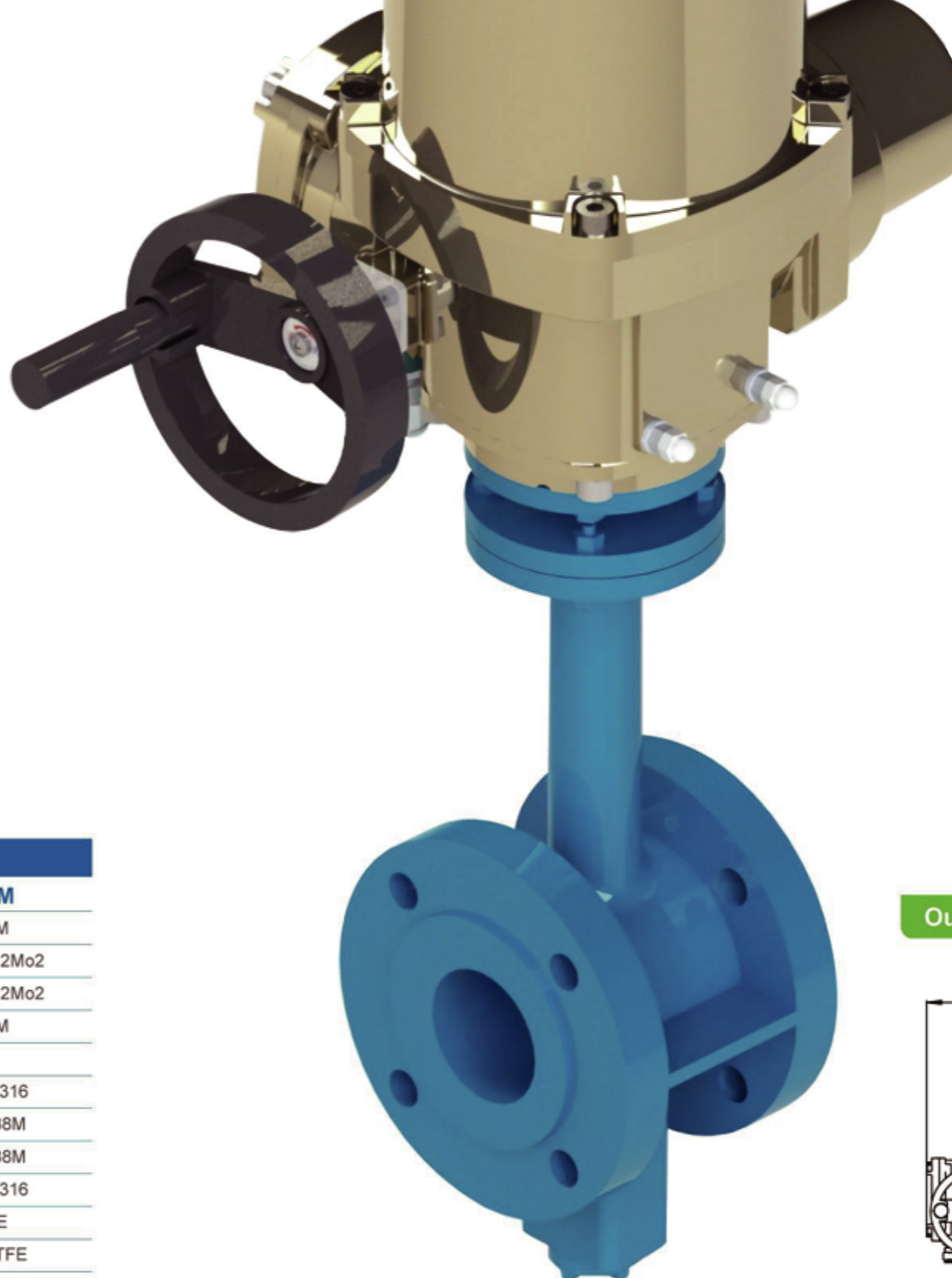

### Parts Material

Name	WCB	WC6	WC9	CF8	CF8M
Body	WCB	WC6	WC9	CF8	CF8M
Key	2Cr13	25Cr2MoV	25Cr2MoV	06Cr19Ni10	0Cr17Ni12Mo2
Stem	2Cr13	25Cr2MoV	25Cr2MoV	06Cr19Ni10	0Cr17Ni12Mo2
Butterfly board	WCB	WC6	WC9	CF8	CF8M
Seal ring	304/316+Graphite		304/316+PTFE		
Platen	A105	A182 F22	A182 F22	A182 F304	A182 F316
Screw	A193 B7	A193 B16	A193 B16	A193 B8	A193 B8M
Bolt-1	A193 B7	A193 B16	A193 B16	A193 B8	A193 B8M
Bottom cover	A105	A182 F22	A182 F22	A182 F304	A182 F316
Gasket	Flexible graphite			PTFE	PTFE
Lower bushing	304+PTFE	304+PTFE	304+PTFE	304+PTFE	316+PTFE
Upper bushing	304+PTFE	304+PTFE	304+PTFE	304+PTFE	316+PTFE
Packing pad	A182 F304	A182 F304	A182 F304	A182 F304	A182 F316
Filler	Flexible graphite			PTFE	PTFE
Bolt-2	A193 B7	A193 B16	A193 B16	A193 B8	A193 B8M
Packing sleeve	WCB	WC6	WC9	CF8	CF8M
Nut	A194 2H	A194 7	A194 7	A194 8	A194 8M
Bolt-3	A193 B7	A193 B16	A193 B16	A193 B8	A193 B8M
Support	WCB	WC6	WC9	CF8	CF8M

### Outline Drawing

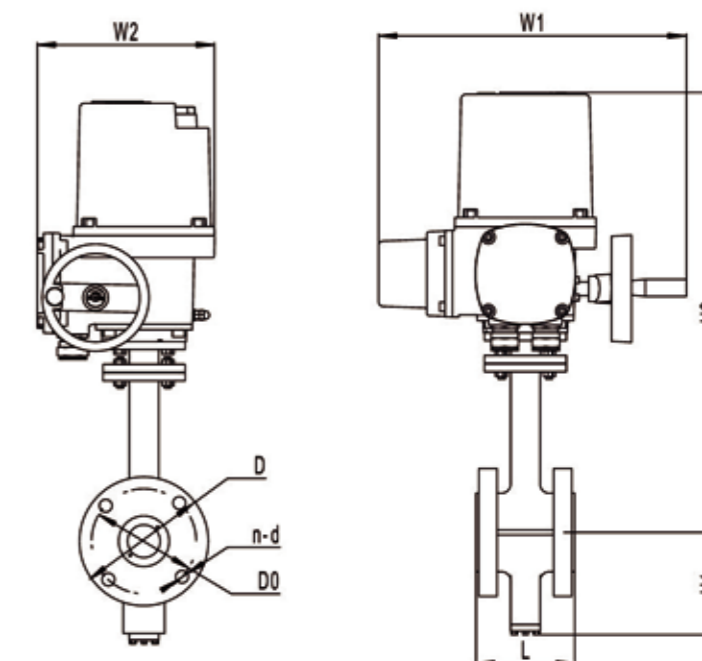

# TRIPLE OFFSET BUTTERFLY VALVE



### Product Advantages

- 'Cam-action' and 'right angled' conical sealing design ensures that the metal sealing components are never in contact until their final degree of closing – this results in repeatable sealing and a vastly extended valve life.
- Metal-to-Metal sealing ensures bubble-tight shut-off, resulting in zero-leakage performance.
- Suitability to harsh media – construction of the valve features no elastomers or materials typically affected by corrosion.
- Geometric design of sealing components provides friction-free stroking throughout the valve. This extends the valve life and allows a lower-torque actuator to be fitted.
- There are no cavities between sealing components, resulting in no clogging, low maintenance and extended valve life.

Main connection and external dimensions(mm)

ISO PN16/25/40																						
Nominal Diameter		PN16							PN25							PN40						
mm	L	H1	H2	W1	W2	D	D0	n-d	H1	H2	W1	W2	D	D0	n-d	H1	H2	W1	W2	D	D0	n-d
DN50	108	85	415	250	182	165	125	4-18	108	375	250	182	165	125	4-18	108	375	250	182	165	125	4-18
DN65	112	100	425	250	182	185	145	4-18	118	385	250	182	185	145	4-18	118	385	250	182	185	145	8-18
DN80	114	125	437	250	182	200	160	8-18	130	395	250	182	200	160	8-18	130	395	250	182	200	160	8-18
DN100	127	161	467	250	182	220	180	8-18	158	422	250	182	235	190	8-18	158	422	332	248	235	190	8-22
DN125	140	163	483	332	248	250	210	8-18	177	431	332	248	270	220	8-18	177	431	332	248	270	220	8-26
DN150	140	168	488	332	248	285	240	8-22	194	450	332	248	300	250	8-22	194	450	424	346	300	250	8-26
DN200	152	202	557	424	346	340	295	12-22	230	514	424	346	360	310	12-22	230	514	424	346	375	320	12-30
DN250	165	235	594	424	346	405	355	12-26	260	558	424	346	425	370	12-26	260	558	424	346	450	385	12-33
DN300	178	285	701	424	346	460	410	12-26	305	668	424	346	485	430	12-26	305	668	424	346	515	450	16-33
DN350	190	315	735	424	346	520	470	16-26	332	710	424	346	555	490	16-26	332	710	424	346	580	510	16-36
DN400	216	360	763	424	346	580	525	16-30	365	733	424	346	620	550	16-30	365	733	424	346	660	586	16-39
DN450	222	386	797	424	346	640	585	20-30	408	780	424	346	670	600	20-30	408	780	780	640	685	610	20-39
DN500	229	402	823	424	346	715	650	20-33	453	816	424	346	730	660	20-33	453	816	812	640	755	670	20-42
DN600	267	489	852	780	640	840	770	20-36	520	846	780	640	845	770	20-36	520	846	1042	640	890	795	20-48
DN700	292	515	906	812	640	910	840	24-36	580	916	812	640	960	875	24-36	580	916	1042	640	1085	990	24-39
DN800	318	636	996	1042	640	1025	950	24-39	635	971	1042	640	1085	990	24-39	635	971	1042	640	1185	1090	28-39
DN900	330	636	1041	1042	640	1125	1050	28-39	665	1031	1042	640	1185	1090	28-39	665	1031	1042	640	1185	1090	28-39
DN1000	410	695	1101	1042	640	1255	1170	28-42	695	1086	1042	640	1320	1210	28-42	695	1086	1042	640	1320	1210	28-42
DN1200	470	815	1414	1512	685	1485	1390	32-48	815	1374	1512	685	1530	1420	32-48	815	1374	1512	685	1530	1420	32-48

\*Pneumatic actuators can be provided and equipped corresponding accessories, such as solenoid valve, positioners, air filter regulator and limit switch according to clients' requirements.

ANSI CLASS150/300																		
Nominal Diameter		ANSI 150							ANSI 300									
Inch	L	H1	H2	W1	W2	D	D0	n-d	L	H1	H2	W1	W2	D	D0	n-d		
2	108	85	415	250	182	152	120.5	4-19	108	108	375	250	182	165	117	8-19		
2-1/2	112	100	425	250	182	178	139.7	4-19	112	118	385	250	182	190	149	8-22		
3	114	125	437	250	182	190	152.5	4-19	180	130	395	250	182	210	168	8-22		
4	127	161	467	250	182	229	190.5	8-19	190	158	422	332	248	254	200	8-22		
5	140	163	483	332	248	254	215.9	8-22	200	177	431	332	248	279	235	8-22		
6	140	168	488	332	248	279	241.5	8-22	210	194	450	424	346	318	270	12-22		
8	150	202	557	424	346	343	298.5	8-22	230	230	514	424	346	381	330	12-25		
10	160	235	594	424	346	406	362	12-25	250	260	558	424	346	444	387.4	16-28.5		
12	178	285	701	424	346	483	431.8	12-25	270	305	668	424	346	521	450.8	16-31.8		
14	190	315	735	424	346	533	476.2	12-28.5	290	332	710	424	346	584	514.4	20-31.6		
16	216	360	763	424	346	597	539.8	16-28.5	310	365	733	424	346	648	571.5	20-35		
18	222	386	797	424	346	635	577	16-31.8	330	408	780	780	640	713	628.6	24-35		
20	229	402	823	424	346	589	635	20-31.8	350	453	816	812	640	775	685.8	24-35		
24	267	489	852	780	640	813	749.3	20-35	390	520	846	1042	640	914	812.8	24-41.1		
28	292	515	906	812	640	837	795.5	40-22	430	580	916	1042	640	921	787	36-35.5		
32	318	636	996	1042	640	887	864	48-22	470	635	971	1042	640	1054	902	32-42		
36	330	636	1041	1042	640	1057	1009.5	44-26	510	665	1031	1512	685	1172	1010	32-45		
40	410	695	1101	1042	640	1175	1121	44-30	550	695	1086	1512	685	1273	1191	40-45		

\*Pneumatic actuators can be provided and equipped corresponding accessories, such as solenoid valve, positioners, air filter regulator and limit switch according to clients' requirements.

# TRUNNION MOUNTED BALL VALVE

## Product Introduction

Trunnion mounted ball valves are quarter-turn valves used to stop the flow of medium in pipelines. These valves feature a round or spherical disk in the center that rotates to start or stop the flow. This disk is called the ball and it features a hollow center.

Ball valves are extremely versatile and are commonly used in industrial applications where tight shut-off is required.



Trunnion ball valves feature additional support part for the ball. This support part is in the shape of a shaft and is called a trunnion. The trunnion absorbs any added pressure from the flow, reducing stress on the ball and valve seats.

Trunnion ball valves are used in high-pressure, large scale applications where low operating torque is required.

## Parts Material

Name	WCB/A105+HCr(ENP)	WCB/304	WCB/316	CF8	CF8M
Body	A216 WCB	A216 WCB	A216 WCB	A351 CF8	A351 CF8M
Bolt-1	A192 2H	A192 2H	A192 2H	A194 8	A194 8M
Nut-1	A193 B7	A193 B7	A193 B7	A193 B8	A193 B8M
O-ring-1	Viton	Viton	Viton	Viton	Viton
Bushing	Metal backed PTFE	Metal backed PTFE	Metal backed PTFE	Metal backed PTFE	Metal backed PTFE
Spacer	A182 F6a	A182 F304	A182 F316	A182 F304	A182 F316
Stem	A182 F6a	A182 F304	A182 F316	A182 F304	A182 F316
Key-1	Carbon steel	Carbon steel	Carbon steel	Stainless steel	Stainless steel
Key-2	Carbon steel	Carbon steel	Carbon steel	Stainless steel	Stainless steel
O-ring-2	Viton	Viton	Viton	Viton	Viton
Gasket	PTFE	PTFE	PTFE	PTFE	PTFE
Gland	A105	A105	A105	A182 F304	A182 F316
Screw	A193 B7	A193 B7	A193 B7	A193 B8	A193 B8M
O-ring-3	Viton	Viton	Viton	Viton	Viton
Ball	A105+HCr(ENP)	A182+F304	A182+F316	A182+F304	A182+F316
Seat	RPTFE	RPTFE	RPTFE	RPTFE	RPTFE
O-ring-4	Viton	Viton	Viton	Viton	Viton
Seat	A105	A105	A105	A182 F304	A182 F316
Spring	SS304/Inconel 750	SS304/Inconel 750	SS316/Inconel 750	SS304/Inconel 750	SS316/Inconel 750
Gasket	PTFE	PTFE	PTFE	PTFE	PTFE
Bolt-2	A192 2H	A192 2H	A192 2H	A192 8	A194 8M
Nut-2	A193 B7	A193 B7	A193 B7	A193 B8	A193 B8M
Cover	A216 WCB	A216 WCB	A216 WCB	A351 CF8	A351 CF8M
Lower shaft	A182 F6a	A182 F304	A182 F316	A182 F304	A182 F316
O-ring-5	Viton	Viton	Viton	Viton	Viton
Adjustment mats	A182 F6a	A182 F304	A182 F316	A182 F304	A182 F316
Lower end cap	A105	A105	A105	A182 F304	A182 F316
Screw	A193 B7	A193 B7	A193 B7	A193 B8	A193 B8M

## Outline Drawing

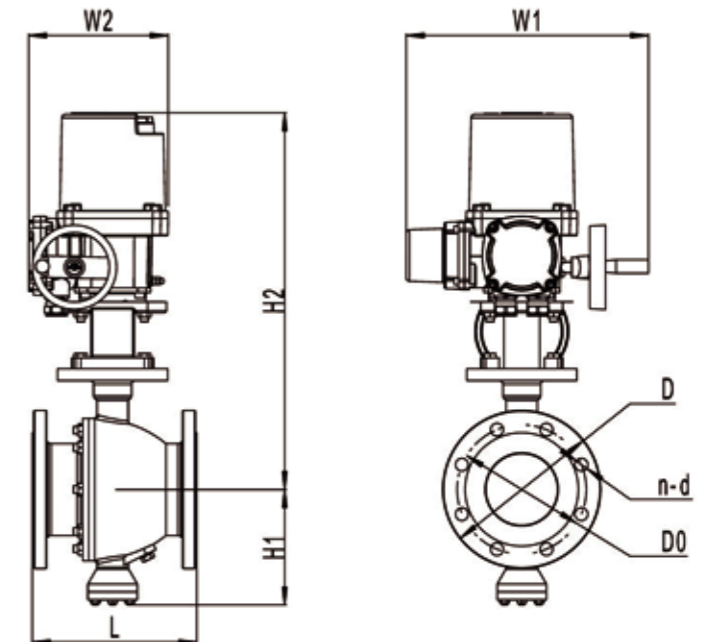



## TRUNNION MOUNTED BALL VALVE

### Product Advantages

#### Double Block And Bleed:

This safety feature eliminates the build up of pressure due to high pressure media trapped in the valve's body cavity, even while the valve is in the fully closed position. Additionally, secondary graphite body seals and flexible graphite packing prevents leakage through the body joints and stuffing box, respectively.

#### Internal Trunnion Design:

Upper and lower bearing plates hold the ball in place, preventing the ball from floating axially and avoiding excess load on the seats. External trunnion design is available in certain sizes.

#### Double Seals On Body Joints:

Primary elastomeric seals ensure zero leakage in standard operating conditions. Secondary graphite seals ensure proper body joint sealing in extreme temperature scenarios.



#### Pressure Energized Stem Packing:

Our proprietary energizer ring, located above the primary o-ring stem seal, provides insurance in the rare event that the O-ring is damaged by using the media pressure to create an upward compressive force on the packing.

This upward force on the packing combined with the downward compressive force created by tightening the packing gland results in a larger net compressive force on the packing and better seal than a typical packing design.

#### Valve Position Indication:

Clear stamping on the outer diameter of the mounting flange identifies the open or close position of the valve based on the stem key orientation.

### Main connection and external dimensions(mm)

ISO PN16/25/40																								
Nominal Diameter	PN16								PN25								PN40							
	L	H1	H2	W1	W2	D	D0	n-d	L	H1	H2	W1	W2	D	D0	n-d	L	H1	H2	W1	W2	D	D0	n-d
DN50	179	97	420	250	182	160	125	4-18	216	97	420	250	182	160	125	4-18	216	105	440	250	182	160	125	4-18
DN65	191	112	440	250	182	180	145	4-18	241	112	440	250	182	180	145	8-18	241	125	460	250	182	180	145	8-18
DN80	203	112	459	250	182	195	160	8-18	283	112	459	250	182	195	160	8-18	283	132	479	250	182	195	160	8-18
DN100	229	122	472	250	182	215	180	8-18	305	122	472	250	182	230	190	8-23	305	132	502	332	248	230	190	8-23
DN125	356	142	482	332	248	245	210	8-18	381	142	482	332	248	270	220	8-25	381	155	512	424	346	270	220	8-25
DN150	394	193	492	424	346	280	240	8-23	457	193	492	424	346	300	250	8-25	457	192	522	424	346	300	250	8-25
DN200	457	240	592	424	346	335	295	12-23	521	240	592	424	346	360	310	12-25	521	246	622	424	346	375	320	12-30
DN250	533	293	648	424	346	405	355	12-25	568	293	648	424	346	425	370	12-30	568	303	678	424	346	445	385	12-34
DN300	610	340	788	424	346	460	410	12-25	648	340	788	424	346	485	430	16-30	648	348	888	812	640	510	450	16-34
DN350	686	372	822	424	346	520	470	16-25	762	372	822	424	346	550	490	16-34	762	378	922	812	640	570	510	16-34
DN400	762	415	922	812	640	580	525	16-30	838	415	922	812	640	610	550	16-34	838	429	1022	1042	640	655	585	20-41
DN450	864	462	1004	812	640	640	585	20-30	914	462	1004	812	640	660	600	20-34	914	518	1104	1042	640	680	610	20-41
DN500	914	511	1152	1042	640	715	650	20-34	991	511	1152	1042	640	730	660	20-41	991	540	1252	1512	685	755	670	20-48
DN600	1067	601	1354	1042	640	840	770	20-36	1143	601	1354	1042	640	840	770	20-41	1143	650	1454	1512	685	890	795	20-48

\*Pneumatic actuators can be provided and equipped corresponding accessories, such as solenoid valve, positioners, air filter regulator and limit switch according to clients' requirements.

ANSI CLASS150/300																
Nominal Diameter	ANSI 150								ANSI 300							
	L	H1	H2	W1	W2	D	D0	n-d	L	H1	H2	W1	W2	D	D0	n-d
2	178	97	420	250	182	152	120.5	4-19	216	105	440	250	182	165	117	8-19
2-1/2	190	112	440	250	182	178	139.7	4-19	241	125	460	250	182	190	149	8-22
3	203	112	459	250	182	190	152.5	4-19	283	132	479	250	182	210	168	8-22
4	229	122	472	250	182	229	190.5	8-19	305	132	502	332	248	254	200	8-22
5	256	142	482	332	248	254	215.9	8-22	381	155	512	424	346	279	235	8-22
6	394	193	492	424	346	279	241.5	8-22	403	192	522	424	346	318	270	12-22
8	457	240	592	424	346	343	298.5	8-22	502	246	622	424	346	381	330	12-25
10	533	293	648	424	346	406	362	12-25	568	303	678	424	346	444	387.4	16-28.5
12	610	340	788	424	346	483	431.8	12-25	648	348	888	812	640	521	450.8	16-31.8
14	686	372	822	424	346	533	476.2	12-28.5	762	378	922	812	640	584	514.4	20-31.6
16	762	415	922	812	640	597	539.8	16-28.5	838	429	1022	1042	640	648	571.5	20-35
18	864	462	1004	812	640	635	577	16-31.8	914	518	1104	1042	640	713	628.6	24-35
20	914	511	1152	1042	640	589	635	20-31.8	991	540	1252	1512	685	775	685.8	24-35
24	1067	601	1354	1042	640	813	749.3	20-35	1143	650	1454	1512	685	914	812.8	24-41.1

\*Pneumatic actuators can be provided and equipped corresponding accessories, such as solenoid valve, positioners, air filter regulator and limit switch according to clients' requirements.

# GLOBE VALVE

## Product Introduction

A Globe valve is a linear motion valve and is primarily designed to stop, start and regulate flow. The disk of a globe valve can be totally removed from the flow path or it can completely close the flow path.

Conventional Globe valves may be used for isolation and throttling service. Although these valves exhibit slightly higher pressure drops than straight-through valves (e.g., gate, plug, ball, etc.), they may be used in applications where the pressure drop through the valve is not a controlling factor.

Globe valves are extensively used to control flow. The range of flow control, pressure drop, and duty must be considered in the design of the valve to avert premature failure and to assure satisfactory service.

Valves subjected to high-differential pressure-throttling service require specially designed valve trim.

Parts Material					
Name	WCB/Trim 1	WCB/Trim 5	WCB/Trim 8	CF8/304	CF8M/316
Body	A216 WCB	A216 WCB	A216 WCB	A351 CF8	A351 CF8M
Seat	A105+13Cr	A105+STL	A105+STL	A351 CF8	A351 CF8M
Disc	A216 WCB+13Cr	A216 WCB+STL	A216 WCB+13Cr	A351 CF8	A351 CF8M
Stem	A182 F6a	A182 F6a	A182 F6a	A182 F304	A182 F316
Disc cover	A216 WCB	A216 WCB	A216 WCB	A351 CF8	A351 CF8M
Bonnet nut	A194 2H	A194 2H	A194 2H	A194 8	A194 8M
Bonnet stud	A193 B7	A193 B7	A193 B7	A193 B8	A193 B8M
Gasket	ASoft Iron+Graphite or 304+Graphite			304+Graphite	316+Graphite
Upper seal	A182 F6a	A182 F6a	A182 F6a	A351 CF8	A351 CF8M
Bonnet	A216 WCB	A216 WCB	A216 WCB	A351 CF8	A351 CF8M
Filler	Flexible graphite				
Pin	ASTM A36	ASTM A36	ASTM A36	304SS	316SS
Screw	A193 B7	A193 B7	A193 B7	A193 B8	A193 B8M
Gland	A182 F6a	A182 F6a	A182 F6a	A182 F304	A182 F316
Press plate	A216 WCB	A216 WCB	A216 WCB	A351 CF8	A351 CF8M
Ring nut	A194 2H	A194 2H	A194 2H	A194 8	A194 8M
Stem nut	A194 2H	A194 2H	A194 2H	A194 8	A194 8M



## Outline Drawing

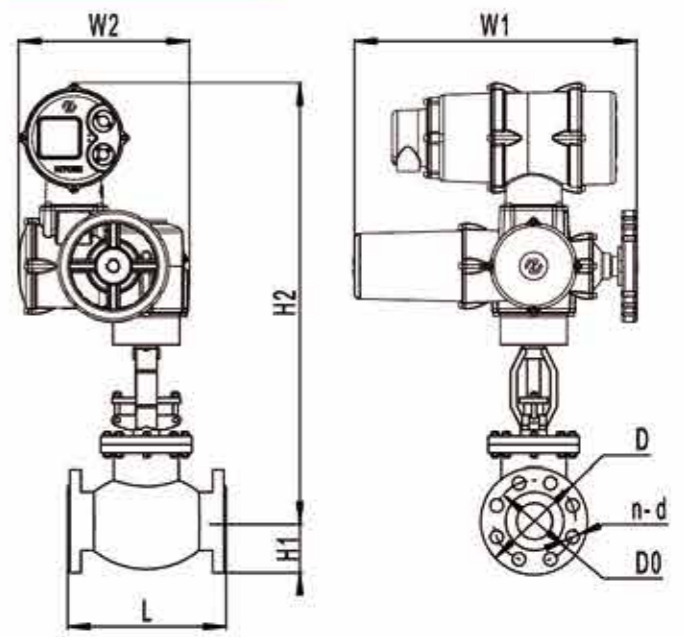

## Product Advantages

- Cooling water systems where flow needs to be regulated.
- Fuel oil systems where flow is regulated and water tightness is of importance.
- High-point vents and low-point drains when water tightness and safety are major considerations.
- Feed water, chemical feed, condenser air extraction and extraction drain systems.
- Boiler vents and drains, main steam vents and drains, and heater drains.
- Turbine seals and drains.
- Turbine lube oil system.

# GLOBE VALVE



Main connection and external dimensions(mm)

ISO PN16								
Nominal Diameter	PN16							
mm	L	H1	H2	W1	W2	D	D0	n-d
DN25	160	58	692	507	306	115	85	4-14
DN32	180	68	698	507	306	135	100	4-18
DN40	200	73	718	507	306	145	110	4-18
DN50	230	80	777	507	306	160	125	4-18
DN65	290	90	823	507	306	180	145	4-18
DN80	310	98	848	507	306	195	160	8-18
DN100	350	108	891	507	306	215	180	8-18
DN125	400	123	898	507	306	245	210	8-18
DN150	480	140	1053	571	354	280	240	8-23
DN200	600	168	1163	571	354	335	295	12-23

ANSI CLASS150								
Nominal Diameter	ANSI 150							
Inch	L	H1	H2	W1	W2	D	D0	n-d
1	127	54	692	507	306	108	79.5	4-15
1-1/4	140	59	698	507	306	117	89	4-15
1-1/2	165	64	718	507	306	127	98.5	4-15
2	203	76	777	507	306	152	120.5	4-19
2-1/2	216	89	823	507	306	178	139.7	4-19
3	241	95	848	507	306	190	152.5	4-19
4	292	115	891	507	306	229	190.5	8-19
5	356	127	898	507	306	254	215.9	8-22
6	406	140	1053	571	354	279	241.5	8-22
8	495	172	1163	571	354	343	298.5	8-22

ISO PN25/40															
Nominal Diameter	PN25								PN40						
	mm	L	H1	H2	W1	W2	D	D0	n-d	H1	H2	W1	W2	D	D0
DN25	160	58	692	507	306	115	85	4-14	58	692	507	306	115	85	4-14
DN32	180	68	698	507	306	135	100	4-18	70	698	507	306	135	100	4-18
DN40	200	73	718	507	306	145	110	4-18	75	718	507	306	145	110	4-18
DN50	230	80	777	507	306	160	125	4-18	83	777	507	306	160	125	4-18
DN65	290	90	823	507	306	180	145	8-18	93	823	507	306	180	145	8-18
DN80	310	98	848	507	306	195	160	8-18	98	848	507	306	195	160	8-18
DN100	350	115	891	507	306	230	190	8-23	115	910	571	354	230	190	8-23
DN125	400	135	917	571	354	270	220	8-25	136	917	571	354	270	220	8-25
DN150	480	150	1053	571	354	300	250	8-25	150	1053	571	354	300	250	8-25
DN200	600	180	1163	571	354	360	310	12-25	188	1210	668	428	375	320	12-30

ANSI CLASS300								
Nominal Diameter	ANSI 300							
Inch	L	H1	H2	W1	W2	D	D0	n-d
1	203	0.5	692	507	306	124	89	4-19
1-1/4	216	18448	698	507	306	133	98.5	4-19
1-1/2	229	18447	718	507	306	156	114.5	4-22
2	267	62	777	507	306	165	127	8-19
2-1/2	292	67	823	507	306	190	149	8-22
3	318	78	848	507	306	210	168	8-22
4	356	83	910	571	354	254	200	8-22
5	400	95	917	571	354	279	235	8-22
6	444	105	1053	571	354	318	270	12-22
8	559	127	1210	668	428	381	330	12-25

\*Pneumatic actuators can be provided and equipped corresponding accessories, such as solenoid valve, positioners, air filter regulator and limit switch according to clients' requirements.

\*Pneumatic actuators can be provided and equipped corresponding accessories, such as solenoid valve, positioners, air filter regulator and limit switch according to clients' requirements.

# GATE VALVE

## Product Introduction

Gate valves are designed for fully open or fully closed service. They are installed in pipelines as isolating valves, and should not be used as control valves.

Operation of a gate valve is performed doing an either clockwise to close (CTC) or clockwise to open (CTO) rotating motion of the stem. When operating the valve stem, the gate moves upwards or downwards on the threaded part of the stem.

Gate valves are often used when minimum pressure loss and a free bore is needed. When fully open, a typical gate valve has no obstruction in the flow path resulting in a very low pressure loss, and this design makes it possible to use a pipe-cleaning pig.

A gate valve is a multi-turn valve, meaning that the operation of the valve is done by a threaded stem. As the valve has to turn multiple times to move from open to closed position, the slow operation also prevents water hammer effects.

Parts Material					
Name	WCB/Trim 1	WCB/Trim 5	WCB/Trim 8	CF8/304	CF8M/316
Body	A216 WCB	A216 WCB	A216 WCB	A351 CF8	A351 CF8M
Gasket	Soft Iron+Graphite or 304+Graphite			304+Graphite	304+Graphite
Seat	A105+13Cr	A105+STL	A105+STL	A351 CF8	A351 CF8M
Gate	A216 WCB+13Cr	A216 WCB+STL	A216 WCB+13Cr	A351 CF8	A351 CF8M
Stem	A182 F6a	A182 F6a	A182 F6a	A182 F304	A182 F316
Upper seal	A182 F6a	A182 F6a	A182 F6a	A351 CF8	A351 CF8M
Filler	Flexible graphite				
Compression sleeve	A182 F6a	A182 F6a	A182 F6a	A182 F304	A182 F316
Screw	A193 B7	A193 B7	A193 B7	A193 B8	A193 B8M
Nut	A194 2H	A194 2H	A194 2H	A194 8	A194 8M
Pin	ASTM A36	ASTM A36	ASTM A36	304SS	316SS
Press plate	A216 WCB	A216 WCB	A216 WCB	A351 CF8	A351 CF8M
Stud	A193 B7	A193 B7	A193 B7	A193 B8	A193 B8M
Nut	A194 2H	A194 2H	A194 2H	A194 8	A194 8M
Bonnet	A216 WCB	A216 WCB	A216 WCB	A351 CF8	A351 CF8M
Nipple	Carbon steel				
Stem nut	A439 D2				
Gland nut	Carbon steel				



## Outline Drawing

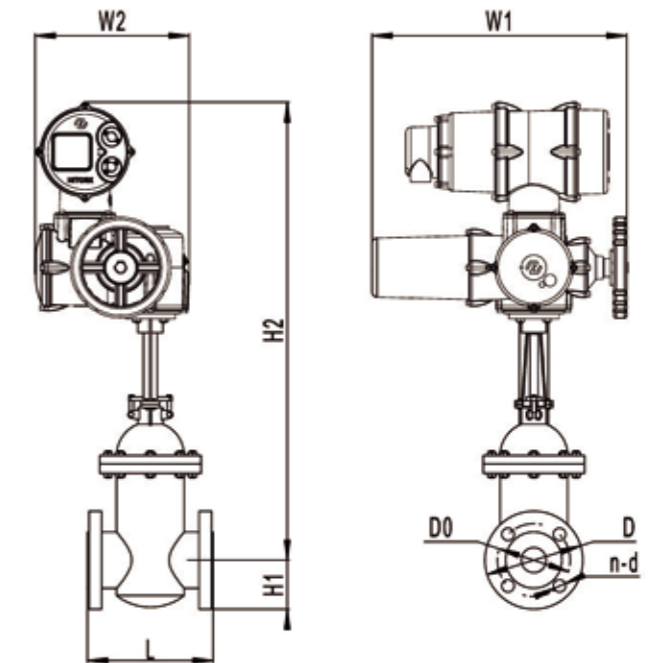

## Product Advantages

- Gate valves are generally found in pipeline systems and in applications where frequent shut off is not required. Large water supply lines use gate valves due to their straight flow path and less flow restrictions.
- Gate valves are used for application with slurries and viscous media because they are easy to clean and maintain.
- Gate valves are used in power plants, mining and water treatment applications which are in high temperature and high-pressure environments.

## GATE VALVE



Main connection and external dimensions(mm)

ISO PN16								
Nominal Diameter	PN16							
mm	L	H1	H2	W1	W2	D	D0	n-d
DN50	250	80	618	507	306	160	125	4-18
DN65	265	90	670	507	306	180	145	4-18
DN80	280	98	700	507	306	195	160	8-18
DN100	300	108	785	507	306	215	180	8-18
DN125	325	123	845	507	306	245	210	8-18
DN150	350	140	990	507	306	280	240	8-23
DN200	400	168	1080	571	354	335	295	12-23
DN250	450	203	1150	571	354	405	355	12-25
DN300	500	230	1415	571	354	460	410	12-25
DN350	550	260	1665	668	417	520	470	16-25
DN400	600	290	1795	668	417	580	525	16-30
DN450	650	320	1920	668	417	640	585	20-30
DN500	700	358	2080	990	571	715	650	20-34
DN600	800	420	2380	990	571	840	770	20-36

ISO PN25/40																
Nominal Diameter	PN25								PN40							
	mm	L	H1	H2	W1	W2	D	D0	n-d	L	H1	H2	W1	W2	D	D0
DN50	250	80	618	507	306	160	125	4-18	250	80	618	507	306	160	125	4-18
DN65	265	90	670	507	306	180	145	8-18	290	90	670	507	306	180	145	8-18
DN80	280	98	700	507	306	195	160	8-18	310	98	700	507	306	195	160	8-18
DN100	300	115	785	507	306	230	190	8-23	350	115	785	507	306	230	190	8-23
DN125	325	135	845	507	306	270	220	8-25	400	135	845	571	354	270	220	8-25
DN150	350	150	990	571	354	300	250	8-25	450	150	990	571	354	300	250	8-25
DN200	400	180	1080	571	354	360	310	12-25	550	188	1080	571	354	375	320	12-30
DN250	450	213	1150	571	354	425	370	12-30	650	223	1150	668	417	445	385	12-34
DN300	500	243	1415	668	417	485	430	16-30	750	255	1415	668	417	510	450	16-34
DN350	550	275	1665	668	417	550	490	16-34	850	285	1685	668	417	570	510	16-34
DN400	600	305	1795	668	417	610	550	16-34	960	328	1815	990	571	655	585	16-41
DN450	650	330	1920	990	571	660	600	20-34								
DN500	700	365	2080	990	571	730	660	20-41								
DN600	800	420	2380	990	571	840	770	20-41								

\*Pneumatic actuators can be provided and equipped corresponding accessories, such as solenoid valve, positioners, air filter regulator and limit switch according to clients' requirements.

ANSI CLASS 150								
Nominal Diameter	ANSI 150							
Inch	L	H1	H2	W1	W2	D	D0	n-d
2	178	76	618	507	306	152	120.5	4-19
2-1/2	190	89	670	507	306	178	139.7	4-19
3	203	95	700	507	306	190	152.5	4-19
4	229	115	785	507	306	229	190.5	8-19
5	254	127	845	507	306	254	215.9	8-22
6	267	140	990	507	306	279	241.5	8-22
8	292	172	1080	571	354	343	298.5	8-22
10	330	203	1150	571	354	406	362	12-25
12	356	242	1415	571	354	483	431.8	12-25
14	381	267	1665	668	417	533	476.2	12-28.5
16	406	299	1795	668	417	597	539.8	16-28.5
18	432	318	1920	668	417	635	577	16-31.8
20	457	345	2080	990	571	589	635	20-31.8
24	508	407	2380	990	571	813	749.3	20-35

ANSI CLASS 300								
Nominal Diameter	ANSI 300							
Inch	L	H1	H2	W1	W2	D	D0	n-d
2	216	83	618	507	306	165	127	8-19
2-1/2	241	95	670	507	306	190	149	8-22
3	283	105	700	507	306	210	168	8-22
4	305	127	785	507	306	254	200	8-22
5	381	140	845	571	354	279	235	8-22
6	403	159	990	571	354	318	270	12-22
8	419	191	1080	571	354	381	330	12-25
10	457	222	1150	668	417	444	387.4	16-28.5
12	502	261	1415	668	417	521	450.8	16-31.8
14	762	292	1685	668	417	584	514.4	20-31.6
16	838	324	1815	990	571	648	571.5	20-35

\*Pneumatic actuators can be provided and equipped corresponding accessories, such as solenoid valve, positioners, air filter regulator and limit switch according to clients' requirements.

## SINGLE SEATED VALVE

### Product Introduction

Single seated valves are one form of globe valves that are very common and quite simple in design. These valves have a few internal parts. They are also smaller than double seated valves and provide good shut-off capability.

Maintenance is simplified due to easy access with top entry to the valve components. Because of their widespread usage, single seated valves are available in a variety of trim configurations, and therefore a greater range of flow characteristics are available. They also produce less vibration due to the reduced plug mass.



### Main Part Name And Material

#### Carbon Steel

Parts Material			
Name	WCB	LCB	WC9
Body	WCB	LCB	WC9
Trim	304	304	304
Gasket	316+Graphite/PTEF		
Bush	304	304	304
Cover	WCB	LCB	WC9
Packing	PTFE/Flexible graphite		
Stem	304	304	304
Bolt	45	40MnB	25Cr2Mo1VA
Nut	35	35	25Cr2Mo1VA

#### Stainless Steel

Parts Material			
Name	CF8	CF8M	CF3M
Body	CF8	CF8M	CF3M
Trim	304	316	316L
Gasket	316+Graphite/PTEF		
Bush	304	316	316L
Cover	CF8	CF8M	CF3M
Packing	PTFE/Flexible graphite		
Stem	304	316	316L
Bolt	304	316	316L
Nut	304	316	316L

- Note: 1. The above is the standard structure of configuration. The connection type of the seat is metal to metal. PTFE soft seal seat is an optional accessory with Class VI seal. Hardened valve trims coated with Staley alloy can also be provided. We will choose suitable nuts and bolts for specific temperature.
2. The standard filler is V ring made of PTFE, and flexible graphite is also available. A valve filled with flexible graphite and with a lengthened bonnet can be used in the condition where the temperature is over 232°C (450°F).
3. The standard body materials are carbon steel and stainless steel. We can also offer alloy materials available in highly corrosive applications.

### Performance

Flow Characteristics	Linear, Equal Percentage, Quick-opening		
Rangeability	50:1(CV<6.3 30:1)		
Rated CV	Equal percentage cv1.6-630, linear cv1.8-690		
Leakage Class	Metal seal: Class IV (0.01% of valve rated capacity) Soft seal: Class VI (bubble level) Leakage		
Performance Table		PNEUMATIC	ELECTRIC
	Intrinsic error %	±1.5	±1.0
	Hysteresis error %	≤1.5	≤1.0
	Dead band %	<0.6	<1.0
	Start tolerance %	±2.5	±2.5
	Standard travel tolerance %	≤2.5	≤2.5

Note: the parameters in the performance table are the control valve and positioner with PTFE packing.

### Outline Drawing

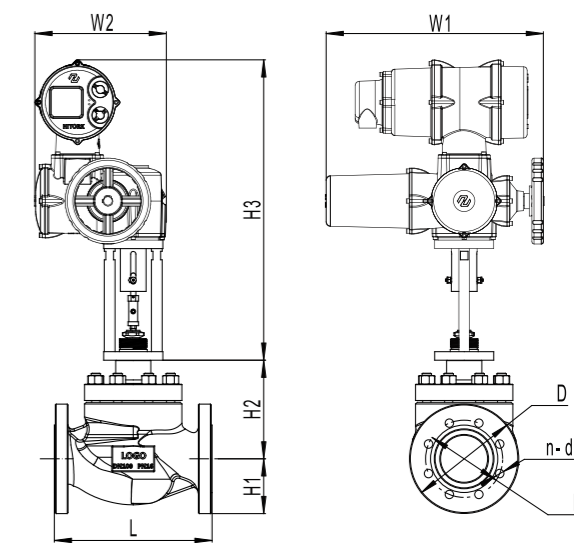

### Parameter Selection Table

Seat Diameter		10	12	15	20	25	32	40	50	65	80	100	125	150	200
Rated Current	Equal Percentage	1.6	2.5	4.0	6.3	10	16	25	40	63	100	160	250	400	630
	Linear	1.8	2.8	4.4	6.9	11	17.6	27.5	44	69	110	176	275	440	690
Nominal diameter		Optional flow coefficient Cv (★standard ●recommended ○customized)													
DN20	16mm	●	●	●	★										
DN25		●	●	●	●	★									
DN32	25mm	○	○	○	○	○	★								
DN40			○	○	○	○	●	★							
DN50				○	○	○	●	●	★						
DN65	40mm						○	○	○	★					
DN80							○	○	○	●	★				
DN100						○	○	○	○	●	●	★			
DN125	60mm								○	○	○	○	★		
DN150										○	○	○	●	★	
DN200										○	○	○	●	●	★

# SINGLE SEATED VALVE



## Main connection and external dimensions(mm)

ANSI CLASS150 & ISO PN16													
Nominal Diameter		Dimensions						Connection size					
		PN16&ANSI 150						PN16			ANSI 150		
mm	Inch	L	H1	H2	H3	W1	W2	D	D0	n-d	D	D0	n-d
DN25	1	184	70	137	700	507	354	115	85	4-14	108	79.5	4-15
DN32	1-1/4	200	70	148	700	507	354	135	100	4-14	117	89	4-15
DN40	1-1/2	222	85	152	700	507	354	145	110	4-14	127	98.5	4-15
DN50	2	254	90	159	700	507	354	160	125	4-18	152	120.5	4-19
DN65	2-1/2	276	102.5	218	700	507	354	180	145	4-18	178	139.7	4-19
DN80	3	298	107.5	230	700	507	354	195	160	8-18	190	152.5	4-19
DN100	4	352	125	238	700	507	354	215	180	8-18	229	190.5	8-19
DN125	5	420	125	264	750	507	354	245	210	8-18	254	215.9	8-22
DN150	6	451	172.5	331	750	507	354	280	240	8-23	279	241.5	8-22
DN200	8	600	180	346	780	571	354	335	295	12-23	343	298.5	8-22

\*Pneumatic actuators can be provided and equipped corresponding accessories, such as solenoid valve, positioners, air filter regulator and limit switch according to clients' requirements.

ANSI CLASS300 & ISO PN40													
Nominal Diameter		Dimensions						Connection size					
		PN40&ANSI 300						PN40			ANSI 300		
mm	Inch	L	H1	H2	H3	W1	W2	D	D0	n-d	D	D0	n-d
DN25	1	197	70	137	700	507	354	115	85	4-14	124	89	4-19
DN32	1-1/4	200	70	148	700	507	354	135	100	4-18	133	98.5	4-19
DN40	1-1/2	235	85	152	700	507	354	145	110	4-18	156	114.5	4-22
DN50	2	267	90	159	700	507	354	160	125	4-18	165	217	8-19
DN65	2-1/2	292	102.5	218	700	507	354	180	145	8-18	190	149	8-22
DN80	3	317	107.5	230	700	507	354	195	160	8-18	210	168	8-22
DN100	4	368	125	238	730	507	354	230	190	8-23	254	200	8-22
DN125	5	420	125	264	750	507	354	270	220	8-25	279	235	8-22
DN150	6	473	172.5	331	750	507	354	300	250	8-25	318	270	12-22
DN200	8	600	180	346	780	571	354	375	320	12-30	381	330	12-25

\*Pneumatic actuators can be provided and equipped corresponding accessories, such as solenoid valve, positioners, air filter regulator and limit switch according to clients' requirements.

# SINGLE SEATED VALVE (CAGE)

## Product Introduction

Cage Type Single Seated Control Valves are designed for high differential pressure heavy duty service where flashing/cavitation may occur. Further, they are ideal for preventing erosion from the valve body, because their guides are sturdy and the valve body is protected by a cage. The compact valve body, with an S-shaped flow passage that features low pressure loss, allows a large flow capacity and range ability.

The valve plug is highly vibration-resistant as it is held by a top guide section which has a large sliding area. The flow shut-off performance complies with the IEC or JIS Standards. The actuator, integrated with simplest mechanisms, utilizes a compact yet powerful diaphragm actuator loaded with multiple springs.

Cage Type Single Seated Control Valves are widely applicable for reliable control of flows in high- or low-temperature, high differential pressure process lines.

## Performance

Flow Characteristics	Linear, Equal Percentage, Quick-opening		
Rangeability	50:1		
Rated CV	Equal percentage cv10~1400 linear cv11~1500		
Leakage Class	Metal seal: Class IV (0.5% of valve rated capacity) Soft seal: Class VI (bubble level) Leakage		
Performance Table		PNEUMATIC	ELECTRIC
	Intrinsic error %	±1.5	±1.0
	Hysteresis error %	≤1.5	≤1.0
	Dead band %	< 0.6	< 1.0
	Start tolerance %	±2.5	±2.5
Standard travel tolerance %	≤2.5	≤2.5	

Note: the parameters in the performance table are the control valve and positioner with PTFE packing.

## Cage Single Seated Valve

### Main connection and external dimensions(mm)

ANSI CLASS150 & ISO PN16														
Nominal Diameter	Dimensions PN16&ANSI 150							Connection size						
	mm	Inch	L	H1	H2	H3	W1	W2	PN16			ANSI 150		
									D	D0	n-d	D	D0	n-d
DN25	1	184	70	137	700	507	354	115	85	4-14	108	79.5	4-15	
DN32	1-1/4	200	70	148	700	507	354	135	100	4-14	117	89	4-15	
DN40	1-1/2	222	85	152	700	507	354	145	110	4-14	127	98.5	4-15	
DN50	2	254	90	159	700	507	354	160	125	4-18	152	120.5	4-19	
DN65	2-1/2	276	102.5	218	700	507	354	180	145	4-18	178	139.7	4-19	
DN80	3	298	107.5	230	700	507	354	195	160	8-18	190	152.5	4-19	
DN100	4	352	125	238	700	507	354	215	180	8-18	229	190.5	8-19	
DN125	5	420	125	264	750	507	354	245	210	8-18	254	215.9	8-22	
DN150	6	451	172.5	331	750	507	354	280	240	8-23	279	241.5	8-22	
DN200	8	600	180	346	780	571	354	335	295	12-23	343	298.5	8-22	
DN250	10	650	274	405	780	571	354	405	355	12-25	406	362	12-25	
DN300	12	745	304	465	780	571	354	460	410	12-25	483	431.8	12-25	

ANSI CLASS300 & ISO PN40														
Nominal Diameter	Dimensions PN40&ANSI 300							Connection size						
	mm	Inch	L	H1	H2	H3	W1	W2	PN40			ANSI 300		
									D	D0	n-d	D	D0	n-d
DN25	1	197	70	137	700	507	354	115	85	4-14	124	89	4-19	
DN32	1-1/4	200	70	148	700	507	354	135	100	4-18	133	98.5	4-19	
DN40	1-1/2	235	85	152	700	507	354	145	110	4-18	156	114.5	4-22	
DN50	2	267	90	159	700	507	354	160	125	4-18	165	217	8-19	
DN65	2-1/2	292	102.5	218	700	507	354	180	145	8-18	190	149	8-22	
DN80	3	317	107.5	230	700	507	354	195	160	8-18	210	168	8-22	
DN100	4	368	125	238	730	507	354	230	190	8-23	254	200	8-22	
DN125	5	420	125	264	750	507	354	270	220	8-25	279	235	8-22	
DN150	6	473	172.5	331	750	507	354	300	250	8-25	318	270	12-22	
DN200	8	600	180	346	780	571	354	375	320	12-30	381	330	12-25	
DN250	10	660	274	405	780	571	354	445	385	12-34	444	387.4	16-28.5	
DN300	12	785	304	465	800	571	354	510	450	16-34	521	450.8	16-31.8	

\*Pneumatic actuators can be provided and equipped corresponding accessories, such as solenoid valve, positioners, air filter regulator and limit switch according to clients' requirements.



## Parameter Selection Table

Seat Diameter		25	32	40	50	65	80	100	125	150	200	250	300
Rated Current	Equal Percentage	10	16	25	40	63	100	160	250	400	630	1000	1400
	Linear	11	17.6	27.5	44	69	110	176	275	440	690	1100	1500
Nominal diameter		Optional flow coefficient Cv ( ★standard ●recommended ○customized )											
DN25	16mm	★											
DN32	25mm	○	★										
DN40		○	●	★									
DN50		○	●	●	★								
DN65	40mm		○	○	○	★							
DN80			○	○	○	●	★						
DN100			○	○	○	●	●	★					
DN125	60mm					○	●	○	★				
DN150							○	○	●	★			
DN200								○	●	●	★		
DN250	100mm								○	●	●	★	
DN300									○	●	●	★	★